



«TiSO-PRODUCTION» Company

**SERVO-OPERATED
WAIST-HIGH TURNSTILE
T3.TYK.XE**



TWIX

**OPERATION MANUAL
AUIA.137C OM**

2013

CONTENTS

	Page
INTRODUCTION	3
1 DESCRIPTION AND OPERATION	5
1.1 General Information and Designation.....	5
1.2 Specifications.....	6
1.3 Configuration and Completeness of Delivery.....	6
1.4 Design and Operation.....	7
1.5 Instrumentation, tools and accessories.....	8
1.6 Marking.....	8
1.7 Packing.....	9
1.8 Description and operation of controller as component of the turnstile.....	9
2 INTENDED USE.....	17
2.1 Operating limitations.....	17
2.2 Layout and installation.....	17
2.3 Preparation for use.....	18
2.4 Contingency actions.....	20
3 MAINTENANCE.....	20
3.1 General instructions.....	20
3.2 Safety measures.....	20
3.3 Maintenance procedure.....	20
4 ROUTINE MAINTENANCE.....	21
4.1 General instructions.....	21
4.2 Fault Directory.....	21
4.3 Post repair checkout.....	21
5 TRANSPORTATION AND STORAGE	21
6 UTILIZATION.....	22
7 MANUFACTURER’S WARRANTY AND CONDITIONS OF INTERMEDIATE MAINTENANCE.....	22
Appendix A Design, overall and installation dimensions of the servo-operated waist- high turnstile T3.TYK.XE	23
Appendix B Control panel.....	24
Appendix C Wiring diagram of the turnstile T3.TYK.XE.	25

INTRODUCTION

This Operation Manual (hereinafter referred to as the OM), combined with certificate, covers servo-operated waist-high turnstile (hereinafter referred to as the turnstile). The Operation Manual contains information about design, specifications, installation, proper operation and maintenance of the turnstile.

This Operation Manual is prepared in compliance with the specification requirements TU U 31.6-32421280-004:2010.

The turnstile should be serviced only by the qualified staff having the relevant class of permit to work with electrical facilities with voltage up to 1000V, who carefully studied this Operation Manual, obtained safety instructions and trained for operation and maintenance of the turnstile.

Reliability and durability of the turnstile operation is provided with observation of modes and conditions of transportation, storage, installation and operation. So, fulfillment of all requirements specified in this document is mandatory.

In view of regularly performed works on improvement of the product, its design can be modified without degradation of parameters and quality of the product.

Depending on the purpose and design features of the turnstile, the following pattern of product reference designation is accepted:

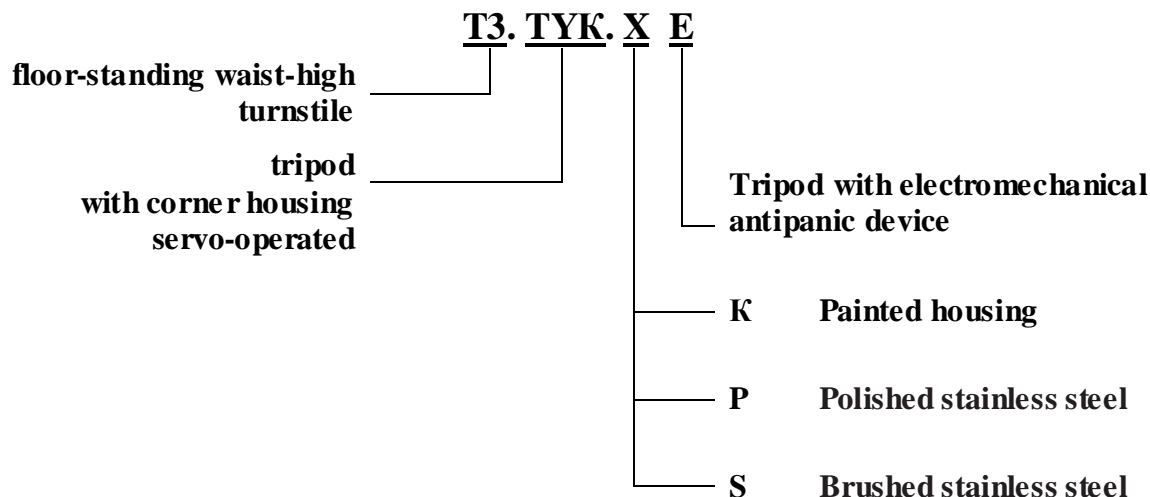

Example of reference designation of the servo-operated turnstile with solid housing from brushed stainless steel when the turnstile

T3.TYK.SE TU U 31.6-32421280-004:2010 is ordered.

WARNINGS TO THE CUSTOMER ON SAFE OPERATION OF THE TURNSTILE

These warnings are designed for ensuring of safety during operation of the turnstile to prevent violation of safety characteristics by improper installation or operation. These warnings are aimed at drawing attention of the customer to safety problems.

GENERAL WARNINGS

Safety measures and requirements specified in this in this OM must be observed:

- the turnstile must be connected to ground loop prior to operation;
- the turnstile should be connected to AC network with parameters specified in the paragraph 1.2 «Specifications»;
- inspection, adjustment and repair should be performed only after the turnstile is deenergized.

After purchasing of the turnstile it should be unpacked and its integrity should be checked. In case of doubt in integrity of the turnstile it should not be used and the customer should refer to the supplier or to the manufacturer.

Packing accessories (wooden pallet, nails, clips, polyethylene bags, cardboard etc.) as potential sources of hazard must be removed to unacceptable place prior to proper use of the turnstile.

As electric shock protection device the turnstile is related to 01 protection class according to the GOST (State Standard) 12.2.007.0-75 and is not intended for operation in explosive and fire-hazardous areas by the «Rules for design of electrical installations».

Using of the turnstile for unintended purpose, improper installation, nonobservance of conditions of transportation, storage, installation and operation specified by this OM, may result in damage to people, animals or property for which the manufacturer is not responsible.

1 DESCRIPTION AND OPERATION

1.1 General Information and Designation

1.1.1 Name of product: Servo-operated waist-high turnstile

Climatic version: NF4

1.1.2 The turnstile is designed for pedestrian movement control at access points of industrial enterprises, banks, stadiums, administrative facilities etc. under actuation of control signals (coming from magnetic card readers, keypad etc.) of access control system or manually (from control panel).

Traffic flow capacity of the turnstile without personal identification is at least 25 persons per minute.

1.1.3 Dimensions and weight of the turnstile correspond to the values specified in the Table 1.

Table 1

Designation of type	Dimensions, mm			Max. weight, kg
	H	L	B	
T3.TYK.KE	1045	744	1004	45
T3.TYK.PE				
T3.TYK.SE				

1.1.4 The parameters defining operation conditions according to GOST 15150-69 and GOST 12997-84 are specified in the Table 2.

Table 2

Operation conditions	For climatic version	Parameter value
Ambient temperature	NF4	+1 to +40°C
Relative humidity		80% at +20°C
Ambient temperature allowable pressure		84 to 106,7kPa
Transportation temperature range		- 40°C to + 50°C
Storage temperature range		+ 5 to + 40°C
Group of mechanical application		L3
Altitude above sea level		up to 2000m
Environment		Explosion-proof, does not contain current-conducting dust, aggressive gases and vapours in concentration destroying isolation and metals, disturbing normal operation of the equipment installed in turnstiles
Installation site		In enclosed spaces in the absence of direct impact of precipitations and solar radiation
Running position		Vertical, deviation from vertical position no more than 1° to any side is tolerated

1.1.5 Reliability indices:

- mean time to repair (without delivery time of spare parts, tools and accessories) – at most 6 hours;
- mean time to failure – at least 1 500 000 accesses;
- mean service life between overhauls – at least 10 years.

1.2 Specifications

Principal parameters of the turnstile are specified in the Table 3.

Table 3

Parameter description	Unit measure	Parameter value
Traffic flow capacity in free access mode is at least	man/min.	60
Traffic flow capacity in single access mode is at least	man/min.	25
Max. passage width	mm	560
Supply voltage:		
– AC power supply (primary)	V Hz	100÷240 ~ 50/60
– DC power supply (secondary)	B	12
Max. power consumption	V·A	75
Index of protection according to GOST 14254-96	–	IP41

1.3 Configuration and Completeness of Delivery

1.3.1 Turnstile design

1.3.1.1 Design of servo-operated waist-high turnstile includes the following principal devices and components:

- corner housing, inside of which there are installed;
- top and side covers;
- two posts;
- LED displays;
- hub with three barrier rods;
- servomotor;
- control panel.

Optionally the turnstile can be completed with battery.

Modification, overall and fitting dimensions of the turnstile are shown in the Appendix A.

The turnstile's design – with electromechanical antipanic device (reference designation T3.TYK.XE).

1.3.1.2 The turnstile modifications are manufactured from:

- polished stainless steel (reference designation T3.TYK.PE);
- brushed stainless steel (reference designation T3.TYK.SE);
- carbon steel subject to painting (reference designation T3.TYK.KE).

1.3.2 Completeness of Delivery

For convenience of delivery the turnstile is supplied ready-to-install with lowered barrier rods.

The turnstile is delivered by one package. Separately packed components are enclosed to the turnstile packing, dimensions of which are 430x1194x1155 mm.

Completeness of delivery is specified in the Table 4.

Table 4

Name of product	Product designation/parameters	Quantity, piece	Notes
Servomotor waist-high turnstile	T3.TYK._____	1	–
<u>Additional parts</u>			
Control panel	AUIA.114.02.00.00	1	–
Battery*	12V; 7A·h	1	Backup Power Supply
Mounting kit	Redibolt 92F112A2-0 (12×120 M10)	4	Anchor with jacket and screw

Certificate	AUIA.137C PS	1	–
Packing	–	1	–
* Optional			

1.4 Design and operation

1.4.1 Turnstile design

1.4.1.1 The turnstile housing is a metal structure to be fastened to two posts. The posts are mounted to plain surface with support by means of Redibolt. Control mechanism and hub with three barrier rods are located on upper part of the turnstile housing (see Appendix A). Two LED displays are installed on upper cover of housing. LED display is designed for indication of authorized access direction (green LED) or banning of access (red LED).

1.4.1.2 The turnstile's control mechanism includes drive with electromagnetic brake. Hub with barrier rods is installed on the drive shaft. Barrier rods are located at the angle 120°. In the initial state one of barrier rods is located horizontally blocking the turnstile access.

1.4.1.3 The turnstile's drive with motor-reducer worm gear shown in Figure 1 provides locking and bringing of barrier rods to initial position after each turnstile access.

1.4.1.4 The panel on which controllers with electronic components and connectors for external connections are installed inside the turnstile housing under the top cover. The controller operates the turnstile motor analyzing signals from speed and position sensors and provides motor overloade protection. Receiving control commands from external devices (control panel, ACS, etc.) the controller controls LED display and generates feedback signals for ACS (Access Control System).

1.4.1.5 Control panel is made as small desktop device in plastic case designed for setting and indication of operating modes when the turnstile is operated manually. Control panel and its connection diagram are shown in the Appendix B.

1.4.2 Principle of operation

1.4.2.1 Turnstile operating modes:

- 1) single access in the direction «A» or «B»;
- 2) locking;
- 3) free access in the direction «A» or «B».

1.4.2.2 In the initial state, when solenoid of operating mechanism is energized, barrier rods are locked from turning and access is barred.

1.4.2.3 When permission command for access in the direction «A» or «B» arrives to controller green arrow is lit on LED display in the appropriate direction and barrier rods are unlocked. Servomotor is actuated and turns barrier rods in the appropriate direction when barrier rod is manually gently pushed in the direction of access. After pedestrian turnstile access barrier rods continue to smoothly turn forward (turn additionally) gradually slowing down and when the definite angle is reached they are locked by electromagnetic brake of operating mechanism, where rotation angle is 120°.

In case of emergency the turnstile with antipanic device ensures free access in both directions by means of specially designed hub and barrier rods with electromechanical antipanic device. Barrier rod is dropped and access is unlocked by pushing «PANIC» button on control panel and keeping it pushed within more than 5 sec. or when signal is sent to the relevant input of the turnstile controller.

More detailed description of the turnstile operating modes is given in the paragraph 1.8 «Description and operation of controller as component of the turnstile».

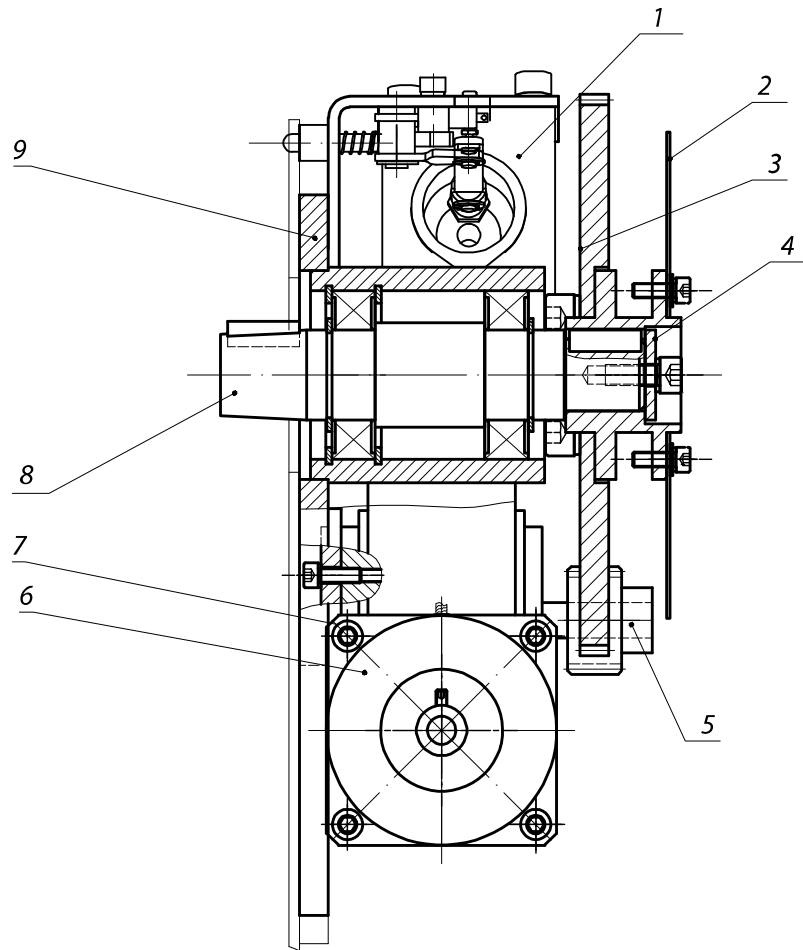

- | | |
|-----------------------|-----------------|
| 1 – unlocking device; | 5 – pinion; |
| 2 – optodisk; | 6 – brake; |
| 3 – gear wheel; | 7 – gear motor; |
| 4 – washer; | 8 – axis; |
| | 9 – base plate |

Figure 1 – Actuator of the turnstile

1.4.2.4 The turnstile 12V DC power voltage is provided by power supply unit.

1.4.2.5 When mains power supply is off, the turnstile is automatically switched to the power supply from 12V, 7A·h battery (optional), which ensures the turnstile's operation within 2 hours.

1.4.2.6 The turnstile's wiring diagram is shown in the Appendix C.

1.5 Instrumentation, tools and accessories

Dedicated tools are required for installation of the turnstile (multi-purpose measurement instrumentation and installation tools are enough).

1.6 Marking

1.6.1 Marking of turnstiles to be delivered within Ukraine is in Ukrainian language and for export delivery in English.

Each turnstile is marked as follows:

- name of manufacturer and trade mark;
- each turnstile is equipped with identification plate containing the following data;
- reference designation of turnstile modification;
- index of protection;
- serial number;

- value of voltage, type of current, frequency and current consumption;
- weight, kg;
- marks of conformity to \oplus , CE ;
- date of manufacture;
- inscription «MADE IN UKRAINE».

Marking plate is located on the turnstile post.

1.6.2 Marking of transportation packing contains as follows:

1) Information inscriptions:

- turnstile reference designation;
- dimensions of cargo package in centimeters;
- gross weight in kg;
- net weight in kg;
- volume of package in cubic meters;

2) Handling marks:

- «Fragile. Handle with Care»;
- «Keep dry»;
- «Centre of gravity»;
- «Top».

1.6.3 Shipping documentation is packed with bag from polyethylene film. Marking is applied on insert from cardboard or paper.

1.7 Packing

1.7.1 The turnstile is delivered ready-to-install.

Types of packing:

- consumer packaging (corrugated cardboard case);
- transportation packaging (cases from wood-fiber board or crates).

The turnstile is fixed from displacement in the middle of transportation package with blocking lumbers. Cushion pads are placed between the turnstile and lumbers.

1.7.2 Shipping documentation sealed in a bag from polyethylene film is enclosed to the turnstile packing.

1.8 DESCRIPTION AND OPERATION OF CONTROLLER AS COMPONENT OF THE TURNSTILE

1.8.1 Controller of motorized device PCB.201.01.00.00

The controller is designed for obtaining commands from control peripherals and generation of motorized device motor and electromagnetic brake control signals.

1.8.1.1 The Controller is assembled on the (85x70)mm card, on which electronic components and connectors for external connections are installed.

On controller card 13 LED s are installed. Their purpose is as follows:

- 8 LEDs indicate condition of inputs «IN1» ÷ «IN8».
- «POWER» LED indicates availability of supply voltage 5V.
- 4 LEDs indicate condition of outputs for connection of motor.

24 terminals are installed on the card: 2 of them are designed for external connections, the rest are designed for connection to turnstile units or are standby.

1.8.1.2 Specifications

Specifications of controller are shown in the Table 5.

Table 5

Parameter description	Parameter value
Number of inputs	2
Number of outputs	4

Type of input	logical
Type of output GRN1, RED1, GRN2, RED2	open collector
Logical «1» voltage	(3,7÷5)V
Logical «0» voltage	(0÷1,7)V
Peak voltage applied to inputs «IN1»÷«IN8», maximum	15V
Peak voltage switched by outputs «GRN1», «RED1», «GRN2», «RED2»	30V
Peak current switched by outputs «GRN1», «RED1», «GRN2», «RED2»	2A
Peak voltage switched by outputs «-MG1», «-MG2»	50V
Peak current switched by outputs «-MG1», «-MG2»	5A
Peak voltage switched by outputs «MOT1», «MOT2»	27V
Peak current switched by outputs «MOT1», «MOT2»	≤ 4A
Controller supply voltage	(10÷27)V
Consumption current when outputs «MOT1» and «MOT2» are OFF	≤0,15A
Climatic modification and placement category of according to the GOST 15150-69	NF4

Appearance of controller is shown in the Figure 2.

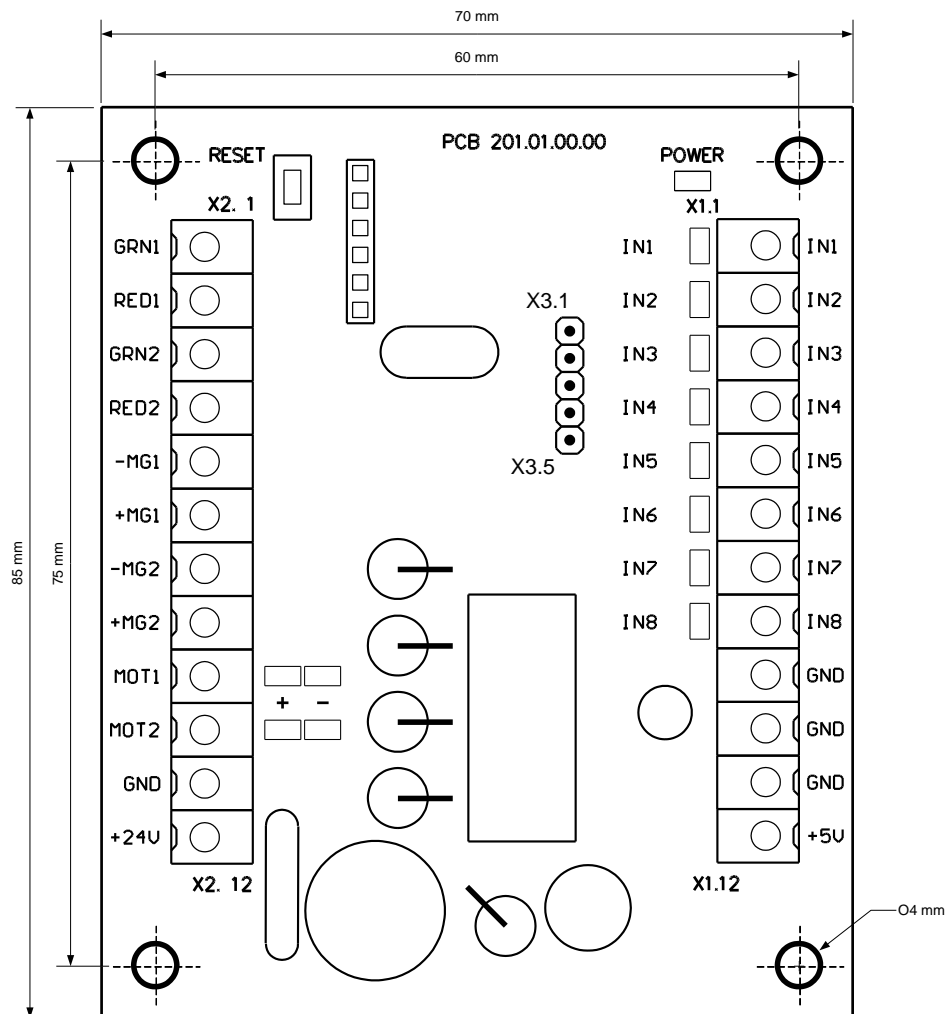

Figure 2 – Appearance of the motorized device controller PCB.201.01.00.00

1.8.1.3 Description of operation

The controller controls DC motor and electromagnetic brake of the turnstile mechanism based on the programmed logic depending on incoming commands, rotor position, rotation speed and motor current. It also provides locking of rotor in initial state, control of rotor turn speed in access mode as well as protection of motor in abnormal situations.

Control commands are generated from the turnstile controller via communication port «X3».

Purpose of controller's contacts designed for connection to peripherals is shown in the Table 6.

Table 6

Connector/ contact No	Designation	Direction	Description	Signal parameters and description
X1/1	IN1	ENTRY	Not applicable	1) logical «0» (0÷1,7)V; 2) logical «1» (3,7÷5)V; 3) active level of signal – logical «0»; 4) voltage on open input ≤ 5V
X1/2	IN2	ENTRY	Not applicable	
X1/3	IN3	ENTRY	Selection of turnstile type	
X1/4	IN4	ENTRY	Not applicable	
X1/5	IN5	ENTRY	To be connected to the sensor of rotor position and motor speed sensor	
X1/6	IN6	ENTRY		
X1/7	IN7	ENTRY		
X1/8	IN8	ENTRY		
X1/9	GND		«-» of power supply (common wire)	
X1/10	GND			
X1/11	GND			
X1/12	+5V	EXIT	Not applicable	
X2/1	GRN1	EXIT	Not applicable	
X2/2	RED1	EXIT	Not applicable	
X2/3	GRN2	EXIT	Not applicable	
X2/4	RED2	EXIT	Not applicable	
X2/5	-MG1	EXIT	Not applicable	1) type of output – open collector; 2) peak voltage on privacy key – 50V; 3) peak current of public key – 5A
X2/6	+MG1	EXIT	Not applicable	
X2/7	-MG2	EXIT	Connection of electromagnetic brake winding	1) type of output – open collector; 2) peak voltage on privacy key – 50V; 3) peak current of public key – 5A
X2/8	+MG2	EXIT	Connection of electromagnetic brake winding (cathode of protective diode)	
X2/9	MOT1	EXIT	Connection of motor	1) voltage (10÷27)V; 2) current ≤ 4A
X2/10	MOT2	EXIT		
X2/11	GND		«-» of power supply (common wire)	
X2/12	+24V	ENTRY	«+» of power supply (controller energizing)	1) voltage (10÷27)V; 2) current ≤ 4A
X3	X3	ENTRY/ EXIT	Communication port	1) logical «0» (0÷1)V; 2) logical «1» (3,5÷5)V

1.8.2 Turnstile controller PCB.112.21.20.00

This controller is designed for obtaining control commands from peripherals (control panel, access control system etc.), generation of feedback signals, LED display control and motorized device control.

1.8.2.1 Controller is assembled on card (104x68)mm and designed for installation into the turnstile housing or power supply box.

19 LEDs are mounted on controller card. Their purpose is as follows:

- 5 LEDs initiate state of inputs for peripheral connections «INP1» ÷ «INP5»;
- LED «POWER» initiates availability of power voltage 5V;
- LED «OPERATE» initiates operability of microprocessor;
- 7 LEDs initiate state of outputs for peripheral connections «OUT1» ÷ «OUT7»;
- 3 LEDs «SENSOR» initiate state of rotor position sensor;
- LEDs «RX» and «TX» initiate respectively reception and transmittance in serial port.

40 connecting terminals are mounted on card, 14 of which are designed for peripheral connections. The rest of them are standby or designed for connection to the turnstile units.

Controller appearance is shown in the Figure 3.

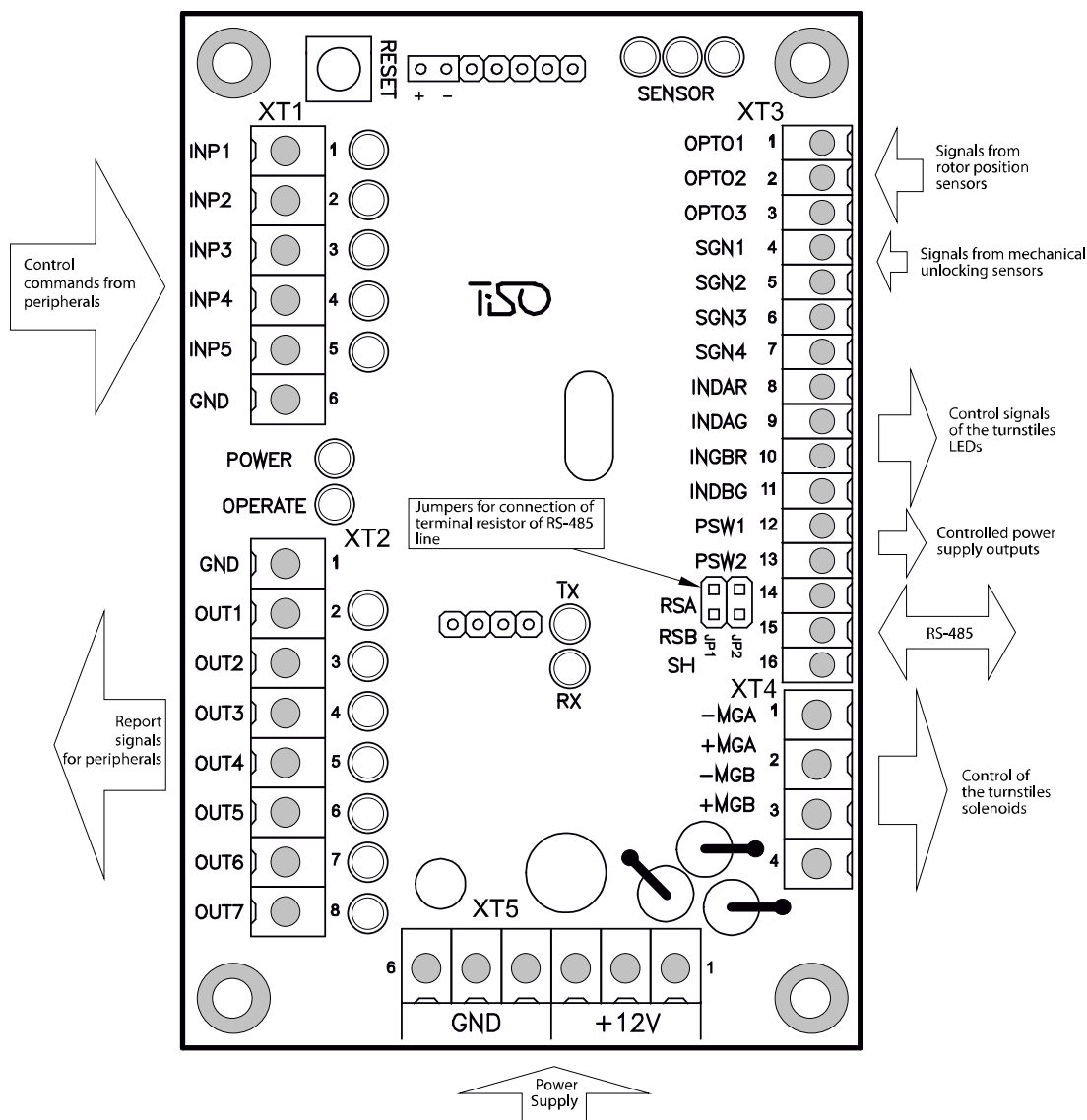

Figure 3 – Appearance of the controller PCB.112.21.20.00

1.8.2.2 Specifications

Controller features are specified in the Table 7.

Table 7

Parameter description	Parameter value
Number of inputs for reception of control commands	5
Number of inputs for connection of rotation sensors	7
Type of inputs	logical
Type of outputs	open collector
Voltage of logical «1»	(3÷5)V
Voltage of logical «0»	(0÷2,2)V
Maximum peak voltage supplied to the inputs «INP1» ÷ «INP5»	15V
Peak voltage switched by transistors of signal outputs	50V
Peak current switched through signal outputs	0,1 A
Power supply voltage of controller	(9÷15)V
Peak consumption current	0,15A
Number of signal reception and transmission serial ports (RS-485)	1
Climatic version and category of location according to the GOST 15150-69	NF4

1.8.2.3 Description of operation

The controller operates according to the program entered into the microprocessor memory. The turnstile's mechanism and LED display is controlled according to control commands and status of rotor position sensors, based on the logic entered into the program. Control commands can be transmitted through RS-485 (from control panel) or logical inputs (by closing and opening of inputs «INP1» ÷ «INP5» on «GND»).

Controller (along with the turnstile) can be in the «INITIAL STATE (closed for access) or in the following access modes:

- «SINGLE ACCESS IN ONE DIRECTION»;
- «FREE ACCESS IN ONE DIRECTION»;
- «LOCKING OF ACCESS».

Other operating modes are combinations of various or similar modes in different directions:

- Single access in one direction and any mode in opposite direction.
- Free access in one direction and any mode in opposite direction.
- Locking of access in one direction and any mode in opposite direction.
- «PANIC» function.

1.8.2.3.1 «INITIAL STATE»

Controller is in this mode, if there are no commands «OPEN A/B» and the turnstile's rotor is set to the point 0°, 120° or 240°.

In this mode solenoids lock rotor: Denied red LED is lit in both directions.

1.8.2.3.2 «SINGLE ACCESS IN ONE DIRECTION»

In this mode the controller sends control command to the motorized device controller resulting in rotor unlocking in one direction with possibility of revolving to 120°. It enables access of one pedestrian through the turnstile.

Controller is switched to «SINGLE ACCESS IN ONE DIRECTION», if in the «INITIAL STATE» it receives «OPEN A/B» command (i.e. active level of signal is sent to the input «INP4» or «INP5»). In this case the turnstile is open within action period of signal. The command can also be sent through RS-485. Then start of rotor rotation is expected prior to the end of delay of «WAITING FOR START OF ACCESS».

Sequence of controller operations after reception of «OPEN A/B» command is as follows:

- Delay of «WAITING FOR START OF ACCESS» is initiated (if command comes from RS-485; factory setting 5 sec.).
- Controller sends control command to the motorized device controller and so rotor is unlocked in the relevant direction.

- LEDs are switched from red to green according to authorized access.

Then two alternatives of events are possible:

- 1) First alternative: If within active status of «OPEN /B» («INP4»/ «INP5») or during delay of «WAITING FOR START OF ACCESS» rotation of rotor is not started, then controller is reset to «INITIAL STATE»;
- 2) Second alternative: If in the above mentioned cases rotation of rotor is started, then further behavior of controller depends on angle of rotor rotation:
 - When rotor is rotated to 6°, LEDs are switched from green to red, indicating that access is occupied. Output signal «START OF ACCESS A/B» («OUT1» or «OUT2») becomes active.
 - When rotor is rotated to 54° the output signal «START OF ACCESS A/B» («OUT1» or «OUT2») is removed. Delay of «WAITING FOR START OF ACCESS» is reset.
 - When rotor is rotated to 64°, the «START OF ACCESS A/B» («OUT3» or «OUT4») signal is generated.
 - When rotor is rotated to 120°, the «OCCUPIED ACCESS A/B» («OUT3») and the «ACCESS DETECTION» («OUT3» or «OUT4») signals are reset and then availability of «A/B TO BE OPENED» («INP4» or «INP5») command, conforming to the actual access direction, is checked. And if by this moment the command remains active, controller switches to «FREE ACCESS» mode, and if it is passive then it resets.

1.8.2.3.3 «FREE ACCESS IN ONE DIRECTION»

In this mode rotor can easily rotate in direction of free access. In the «FREE ACCESS» mode green LED of the relevant direction is blinking.

In this mode transition of controller is occurred in three cases:

- First: when the «OPEN A/B» (input «INP4» or «INP5») command is kept in active status at the moment of crossing by rotor the point 120° at the termination of «SINGLE ACCESS».
- Second: after reception of the «FREE ACCESS» command in the relevant direction through RS-485.

After switching of controller to «FREE ACCESS» mode, output signals of «OCCUPIED ACCESS», «ACCESS DETECTION» of the relevant direction are generated as described in the Table 8.

Exit of this mode in «INITIAL STATE» is taken place after cancellation of the «OPEN A/B» command or reception of the «FREE ACCESS CANCELLATION» command through RS-485. But it will take place not instantly and only when rotor reaches one the starting points 0°, 120° or 240°, i.e. if the free access cancellation arises during the started access it will be completed as free.

1.8.2.3.4 «AUTHORIZATION OF SINGLE ACCESS IN TWO DIRECTIONS»

Since the turnstile having one rotor cannot be rotated in two directions simultaneously, controller can only unlock rotor in two directions and after access in one of directions is stated, the reverse direction will be closed.

Controller is switched to this mode if in the «INITIAL STATUS» it simultaneously acquires «OPEN A» and «OPEN B» commands. The second signal also can come during the time when the first signal is already active but rotation of rotor did not start yet.

In this case:

- 1) Controller sends the relevant command to the motorized device controller to unlock rotor in two directions.
- 2) Switches both LEDs from red to green.
- 3) Initiates two delays of «WAITING FOR START OF ACCESS A and B» (if commands come from RS-485) for each access separately, which are counted from the moment of acquisition of commands.
- 4) Controller waits for start of access.
- 5) After rotor is revolved to 6° in any side, the opposite direction will be locked and LED is switched to red.

Then controller is operating as described in the chapter «SINGLE ACCESS IN ONE DIRECTION».

If during active status of the «OPEN A» and «OPEN B» signals or during «WAITING FOR START OF ACCESS» rotor has not been revolved in any side to the angle more than 6°, controller is switched to the «INITIAL STATE».

1.8.2.3.5 «PANIC FUNCTION»

The turnstile is switched to «PANIC» state:

- after keeping of active state on the input («INP5» «PANIC») more than 1,5 sec;
- after sending of «PANIC» command by means of control panel (command is sent after «PANIC» button to be kept during more than 7 sec.).

After activation of «PANIC» function the barrier rod which is in horizontal position, will be lowered, the output («OUT7» «PANIC») will be switched to active state during action of function.

«PANIC» function is canceled:

- after release of active state on the input «INP5» «PANIC»);
- after sending of command «CANCELATION of PANIC» from control panel (repeated pushing of «PANIC» button).

At the same time in any case the motorized device controller will be sent the relevant command resulting in rotor turning and the barrier rod which was dropped, will take its operation position and fix.

1.8.2.3.6 «LOCKING OF ACCESS»

Locking function can be activated only by control panel.

After activation of «LOCKING OF ACCESS A or B» the turnstile's rotor blocked in the relevant direction and enable access commands will be ignored in locked direction; locked direction is indicated by blinking red color.

Controller's contacts designed for connection of peripherals are shown in the Table 8.

Table 8

Connector /contact No.	Description	Direction	Designation	Signal description and parameters
XT1/1	INP1 («PANIC»)	ENTRY	«SWITCH TO PANIC STATE» command	1) logic «0» (0÷2,2)V; 2) logic «1» (3÷5)V; 3) active level of signal (factory setting) – logic «0»; 4) voltage on open input < 5V
XT1/2	INP2	ENTRY	Not applicable	
XT1/3	INP3	ENTRY		
XT1/4	INP4 («OPEN A»)	ENTRY	«OPEN FOR SINGLE / FREE ACCESS» command. Free access is appeared when entry is kept in active state after rotor reaches the angle 120°	
XT1/5	INP5 («OPEN B»)	ENTRY		
XT1/6	GND (common)		«-» of power supply (common wire)	
XT2/1	GND (common)			
XT2/2	OUT1 («START OF ACCESS A »)	EXIT	Signal is generated by controller when rotor revolves from 6° to 54° in the relevant direction	1) type of output – open collector; 2) peak voltage on public key 55V; 3) peak current of public key 100mA; 4) resistance of public key (5÷7)Ohm; 5) active level of signal (factory setting) – logical «0»
XT2/3	OUT2 («START OF ACCESS B»)	EXIT		
XT2/4	OUT3 (DETECTION OF ACCESS A»)	EXIT	Signal is generated by controller when rotor revolves from 64° to 120° in the relevant direction	
XT2/5	OUT4 («DETECTION OF ACCESS B»)	EXIT		
XT2/6	OUT5 («ACCESS IS OCUPIED»)	EXIT	Signal is generated by controller when rotor revolves from 6° to 120° in any direction	
XT2/7	OUT6	EXIT	Signal is generated by	

	(«ERROR»)		controller when violation of operation logic is detected	
XT2/8	OUT7 («PANIC»)	EXIT	Signal is generated by controller when «PANIC» function is activated	
XT3/1	OPTO1	ENTRY	It is used for acquisition of data about the turnstile's rotor position	1) logical «0» (0÷2,2)V; 2) logical «1» (3÷5)V; 3) active level of signal (factory setting) – logical «0»; 4) voltage on open input < 5V
XT3/2	OPTO2	ENTRY		
XT3/3	OPTO3	ENTRY		
XT3/4	SGN1	ENTRY	Not applicable	
XT3/5	SGN2	ENTRY	Selection of the turnstile type	
XT3/6	SGN3	ENTRY	Not applicable	
XT3/7	SGN4	ENTRY	Not applicable	
XT3/8	INDAR	EXIT	It is used for the turnstile's indication control	1) type of output – open collector; 2) peak voltage on privacy key 30V; 3) peak current of public key 2A; 4) resistance of public key 0,10hm
XT3/9	INDAG	EXIT		
XT3/10	INDBR	EXIT		
XT3/11	INDBG	EXIT		
XT3/12	PSW1 (PANIC)	EXIT	Not applicable	1) type of output – open emitter; 2) voltage on output in ON state 12V; 3) peak current consumed from output 1A; 4) resistance of public key 0,250hm
XT3/13	PSW2 (SENSOR)	EXIT	Not applicable	
XT3/14	RSA		It is used for data transmission through the serial port	Interface RS-485
XT3/15	RSB			Interface RS-485
XT3/16	SH			RS-485 SHIELD
XT4/1	- MGA	EXIT	It is used for energizing of solenoid of barrier rod reset system in «PANIC» function	1) type of output – open collector; 2) peak voltage on public key 50V; 3) peak current of public key 9A; 4) resistance of public key 0,110hm
XT4/3	- MGB	EXIT	Not applicable	
XT4/2	+ MGA		Connection of cathodes of protective diodes to positive terminal of solenoid power supply	
XT4/4	+ MGB		Not applicable	
XT5/1	GND (common)		«-» of power supply	

			(common wire)	
XT5/2	GND (common)			
XT5/3	GND (common)			
XT5/4	+ 12V		«+» of power supply (controller energizing)	1) supply voltage 12V; 2) consumption current < 150mA
XT5/5	+ 12V			
XT5/6	+ 12V			
XP1	XP1	ENTRY/ EXIT	Communication port	1) logical «0» (0÷1)V; 2) logical «1» (3,5÷5)V

2 INTENDED USE

2.1 Operation limitations

2.1.1 The turnstile must be used in the environment specified in the p. 1.1.4 of this document subject to the specifications listed in the section 1.2.

2.1.2 IT IS PROHIBITED:

- 1) **UNINTENDED USE OF THE TURNSTIL** (see the Chapter 1 «DESCRIPTION AND OPERATION»);
- 2) **TO USE THE TURNSTILE UNEARTHED;**
- 3) **TO USE HEATING PIPES AND RADIATIONS AS WELL AS PIPES OF CENTRAL WATER SUPPLY FOR EARTHING;**
- 4) **TO REPAIR AND ADJUST WITHOUT DEENERGIZING;**
- 5) **TO RELOCATE THE OBJECTS EXCEEDING THE PASSAGEWAY WIDTH THROUGH THE TURNSTILE ACCESS AREA;**
- 6) **TO JERK AND IMPACT ON BARRIER RODS, LED DISPLAY OR OTHER PARTS THE PRODUCT, WHICH MAY CAUSE THEIR MECHANICAL DEFORMATION OR DAMAGE.**

2.1.3 It is not allowed to use the turnstile:

- at the presence of mechanical rattle in movable parts of the turnstile;
- when metalwork of the turnstile and its components and accessories are mechanically damaged.

2.1.4 List of special conditions of operation

- Mean time of the turnstile access (in single access mode) equals to 2,4 sec.
- The turnstile's mechanism allows emergency access by means of antipanic device.
- The force applied by accessor to barrier rod should not exceed 60H.
- For augmentation of the turnstile's traffic flow capacity in case of emergency escape door or gate can be installed near the turnstile.

ATTENTION: MANUFACTURER WARNS OF NECESSITY TO KEEP SEALS OF THE MANUFACTURER ON THE TURNSTILE'S COMPONENT PARTS!

2.2 Layout and installation

2.2.1 The turnstile and components of delivery kit are delivered to the installation site in the factory packing. The turnstile should be unpacked only on installation site.

2.2.2 Preparation of the turnstile for installation (dismounting) and commissioning should be performed according to this OM with mandatory observation of the safety measures specified in p. 2.1 and general electrical safety code.

2.2.3 The turnstile is installed in the following order:

- inspect the turnstile for integrity, absence of visual damages and defects;
- verify the turnstile's completeness;

- prepare installation site: surface should be plain, hard and without defects (corrugations, overlaps etc.);
- mark the hole drilling places according to the Appendix A. The turnstile should be installed and fixed only after all electric cables are pulled. The turnstile is fixed with Redibolt (anchor with jacket and screw). Make sure that the installed turnstile is stable;
- earthen the turnstile, connect power cable to the turnstile and control panel according to the wiring diagram (see Appendix C);
- put barrier rod to initial position, then check rotation of hub: the hub should be easily rotated manually with uniform friction.

During installation of the turnstile it is necessary to take into account that horizontally located barrier rod should be on the distance not more than (50÷100)mm from the driver of passage (any surface perpendicular to horizontally located barrier rod: enclosure module, wall etc.).

2.3 Preparation for use

2.3.1 Commissioning instructions

Prior to energizing of the turnstile:

- 1) make sure of proper connection and good condition of all connecting cables;
- 2) clear the area of the turnstile's barrier rod rotation from foreign particles.

When mains cable of power supply unit is connected to the network the solenoids of the turnstile's control mechanism are energized; barrier rods are locked from rotation in both directions and one of barrier rods is located horizontally barring access.

The turnstile is set in initial state: ENTRY and EXIT red LED display (« >< » is lit).

2.3.2 Required inspections

2.3.2.1 When the turnstile is commissioned it is necessary to perform inspections specified in the Table 9. During inspections the wiring diagram according to the Appendix C and the control panel according to the Appendix B should be used.

Table 9

Operation Mode	Operation Mode Setting	LED Display	Functional Check
1 Turnstile is closed in both directions (initial state)	–	Red LEDs are lit from both sides	Make sure that rotor can't be turned in any direction
2 Single access in one direction	Push the button «SINGLE» on control panel for access in the chosen direction («A» or «B»)	Green arrow of authorized single access in the chosen direction is lit and red arrow is lit in opposite direction	Make sure that when gently pushed in the direction of authorized access rotor begins to revolve and stops after turning to 120°. Rotor should not start revolving independently
3 Single access in both directions	Push both buttons «SINGLE» on control panel for access in both directions («A» and «B»)	Green arrows of authorized single access in both directions are lit	Make sure that when gently pushed in the direction of authorized access rotor begins to revolve and stops after turning to 120°. Rotor should not start revolving independently. Repeat the same for opposite direction
4 Free access in one direction	Push the button «FREE» on control	Green arrow of authorized free access	Make sure that at each push in the free access direction rotor

	panel for access in the chosen directions («A» or «B»)	in the chosen direction is blinking and red LED is lit in opposite direction	turns to 120° and stops. Rotor should not start revolving independently
5 Free access in both directions	Push both buttons «FREE» on control panel for access in both directions («A» and «B»)	Green arrows of authorized free access in both directions are blinking	Make sure that at each push in any direction rotor turns to 120° and stops. Rotor should not start revolving independently
6 Single access in one direction and free access in opposite direction	Push the button «SINGLE» on control panel for access in the chosen direction («A» or «B») and the button «FREE» for access in opposite direction	Green arrow of authorized single access in the chosen direction is lit and green arrow of authorized free access in opposite direction is blinking	Make sure that rotor can be turned to 120° in the single access direction one time only and to the free access direction rotor can be turned many times. Rotor should not start revolving independently
7 Single access in one direction and locked access in opposite direction	Push the button «SINGLE» for access in the chosen direction («A» or «B») and the button «LOCK» for locking access in opposite direction	Green arrow of authorized single access in the chosen direction is lit and red LED is blinking in the locked access direction	Make sure that rotor can be turned to 120° in the single access direction one time only and the turnstile can't be switched neither to the «SINGLE» access mode nor to the «FREE» access mode to the locked direction
8 Free access in one direction and locked access in opposite direction	Push the button «FREE» for access in the chosen direction («A» or «B») and the button «LOCK» for locking access in opposite direction	Green arrow of authorized free access in the chosen direction is blinking and red LED is blinking in the locked access direction	Make sure that rotor can be turned to 120° in the free access direction many time and the turnstile can't be switched neither to the «SINGLE» access mode nor to the «FREE» access mode to the locked direction
9 Locked access in one direction	Push the button «LOCK» for locking access in the chosen direction («A» or «B»)*	Red LED of locked access in one chosen direction is blinking	Make sure that the turnstile can't be switched neither to the «SINGLE» access mode nor to the «FREE» access mode in the locked direction
10 Locked access in both directions	Push both buttons «LOCK» for locking access in both directions («A» and «B»)**	Red LED of locked access in both directions is blinking	Make sure that the turnstile can't be switched neither to the «SINGLE» access mode nor to the «FREE» access mode in any direction.
11 Activation of antipanic device	Push the button «PANIC» and don't release it within at least 5 sec	Green arrows of authorized free access in two directions are blinking	Make sure that the barrier rod being in horizontal (uppermost) position was unlocked and dropped to vertical position made the turnstile access open
12 Deactivation of antipanic device	Push the button «PANIC»	Red LEDs are lit from both sides	Make sure that rotor turned and at the same time unlocked barrier rod is in lowermost position and fixed

* In this case other control panel buttons of single and free access in chosen direction are locked

** In this case all control panel buttons of single and free access in two directions are locked

2.3.2.2 When the turnstile is inspected it is ready for long-term operation.

2.4 Contingency actions

For emergency evacuation (in case of fire, acts of God etc.) and providing free access the turnstile must be unlocked from control panel by sending the relevant command. Antipanic device should be used for complete opening of access.

3 MAINTENANCE

3.1 General instructions

3.1.1 Commissioning and subsequent maintenance of the turnstile should be performed only by the staff to be in charge of the turnstile.

3.1.2 The turnstile can be serviced only by the staff having the relevant electrical safety qualification level according to the national requirements.

3.1.3 The turnstile can be installed and operated only by the qualified safety instructed staff having the relevant class of permit to work with electrical facilities with voltage up to 1000V, aware of this OM, design and the turnstile's principle of operation.

3.2 Safety Measures

3.2.1 During maintenance of the turnstile the relevant safety measures, specified in p. 2.1, must be observed.

IT IS FORBIDDEN TO USE DEFECTIVE APPLIANCES, TOOLS, FUSES, INSTRUMENTATION SERVICE LIFE OF WHICH EXPIRED. MEASURING DEVICES, WHICH TERM OF CHECKING EXPIRED.

3.2.2 When instrumentations are prepared for operation it is necessary to comply with the safety requirements specified in instrumentation instruction manuals.

3.3 Maintenance procedure

3.3.1 Maintenance of the turnstile includes preventive measures which are taken according to established frequency to maintain the turnstile in operational condition, decreasing of component wearing and prevention of faults and malfunctions.

3.3.2 Daily and periodic maintenance of the turnstile are recommended.

Normally the daily maintenance is carried out before the beginning of work or during operational timeout and includes visual inspection of the turnstile's housing, and, if required, mechanical troubleshooting, elimination of corrosion and pollution from the surface.

IT IS FORBIDDEN TO USE ABRASIVE AND CHEMICALLY ACTIVE SUBSTANCES DURING CLEANING OF CONTAMINATED EXTERNAL SURFACES OF THE PRODUCT.

3.3.3 Periodic maintenance is performed at least twice a year and includes as follows:

- visual inspection of the turnstile's housing, control mechanism and other components for absence of corrosion, warps and other mechanical defects and pollutions;
- checking of tightness of the turnstile's screw tightening;
- remedy of faults and malfunctions;
- lubrication with the lubricant OKB-122-7 according to the GOST 18179-90 or engine oil of control mechanism locking levers, if necessary.

4 ROUTINE MAINTENANCE

4.1 General instructions

Possible malfunctions of the turnstile listed in the Table 10 are remedied by customer. More complicated malfunctions are remedied by manufacturer's representative.

ATTENTION: INSPECTION, CLEANING, REPAIR OF THE TURNSTILE'S COMPONENTS MUST BE PERFORMED ONLY AFTER DEENERGIZING OF THE TURNSTILE!

4.2 List of possible malfunctions

List of possible malfunctions and their remedies are specified in the Table 10.

Table 10

Symptom	Possible cause	Remedy
1) Turnstile does not operate and LEDs are not lit	Response of current protection circuit breaker located in the turnstile housing	Circuit breaker to be turned on
	Faulted contact in the ~ 220V turnstile connection terminal block	Supply of ~ 220V to the turnstile to be restored
2) When the mains power supply is cutoff the turnstile does not operate from battery	Battery is discharged	Battery to be maintained according to its instruction manual
	Battery service life expired	Battery to be replaced
3) Turnstile does not respond to control panel commands	Faulted connection between control panel and turnstile	Connection between control panel and turnstile to be restored
	Control panel is out of order	Control panel to be replaced

4.3 Postrepair checkout

After repair the turnstile's operating capacity is checked according to p. 2.3.2.

5 TRANSPORTATION AND STORAGE

5.1 It is forbidden to subject the turnstile to jerks and impacts during storage. For lifting and handling of the turnstile it is necessary to use transportation trolleys. In storage facility there should not be aggressive gases and vapours causing corrosion. Storage ambient temperature should not be below +5°C and higher than +40°C and relative humidity should not be more than 80% at the temperature 20°C.

5.2 The ready-to-install turnstile is transported in railway or special containers, closed vehicle, waterborne (in ship's hold) according to the transportation regulations related to the relevant mode of transport.

Transportation on open platforms is allowed. In this case the packed turnstile should be covered with canvas. Ambient temperature during transportation should not be lower than - 40°C and higher than +50°C.

After transportation or storage of the turnstile at negative temperatures or increased humidity the turnstile should be kept indoor with normal climatic conditions without original packing within 12 hours before commissioning:

- 1) ambient temperature: + 15°C to +35°C;
- 2) relative humidity: 45% to 80 %;
- 3) atmospheric pressure: 84,0 to 106,7 kPa (630-800 mm Hg).

6 UTILIZATION

The turnstile does not contain hazardous materials and special measures are not required for utilization.

7 MANUFACTURER'S WARRANTY AND CONDITIONS OF WARRANTY MEAINTEANCE

7.1 The manufacturer guarantees good state and declared quality of the turnstile if conditions of transportation, storage, installation and operation are observed by the consumer.

7.2 The warranty period of the turnstile from the date of sale is 12 months, unless otherwise specified by mutual agreement.

Manufacturer:
«**TISO-PRODUCTION**» **Company**
72 Yamskaya str., 03680, Kiev, Ukraine
Tel.: +38 (044) 461-79-69
Tel./Fax: +38 (044) 586-46-47
E-mail: export@tiso.ua, log1@tiso.ua
www.tiso-turnstiles.com

Our equipment complies with requirements of the European Standards:

EN ISO 12100:2010; EN 614-1:2006+A1:2009; EN 1037:1995+A1:2008; EN 60204-1:2006; EN 953:1997+A1:2009; ISO 3864:1995; EN ISO 13857:2008; EN ISO 13849-1:2006; EN 1088:1995; EN ISO 13732-1:2008

and is in conformity with requirements of the following EC Directives:

2004/108/EC; 2006/95/ EC; 2006/42/ EC



Appendix A

Design, overall and installation dimensions of turnstile T3.TYK.XE

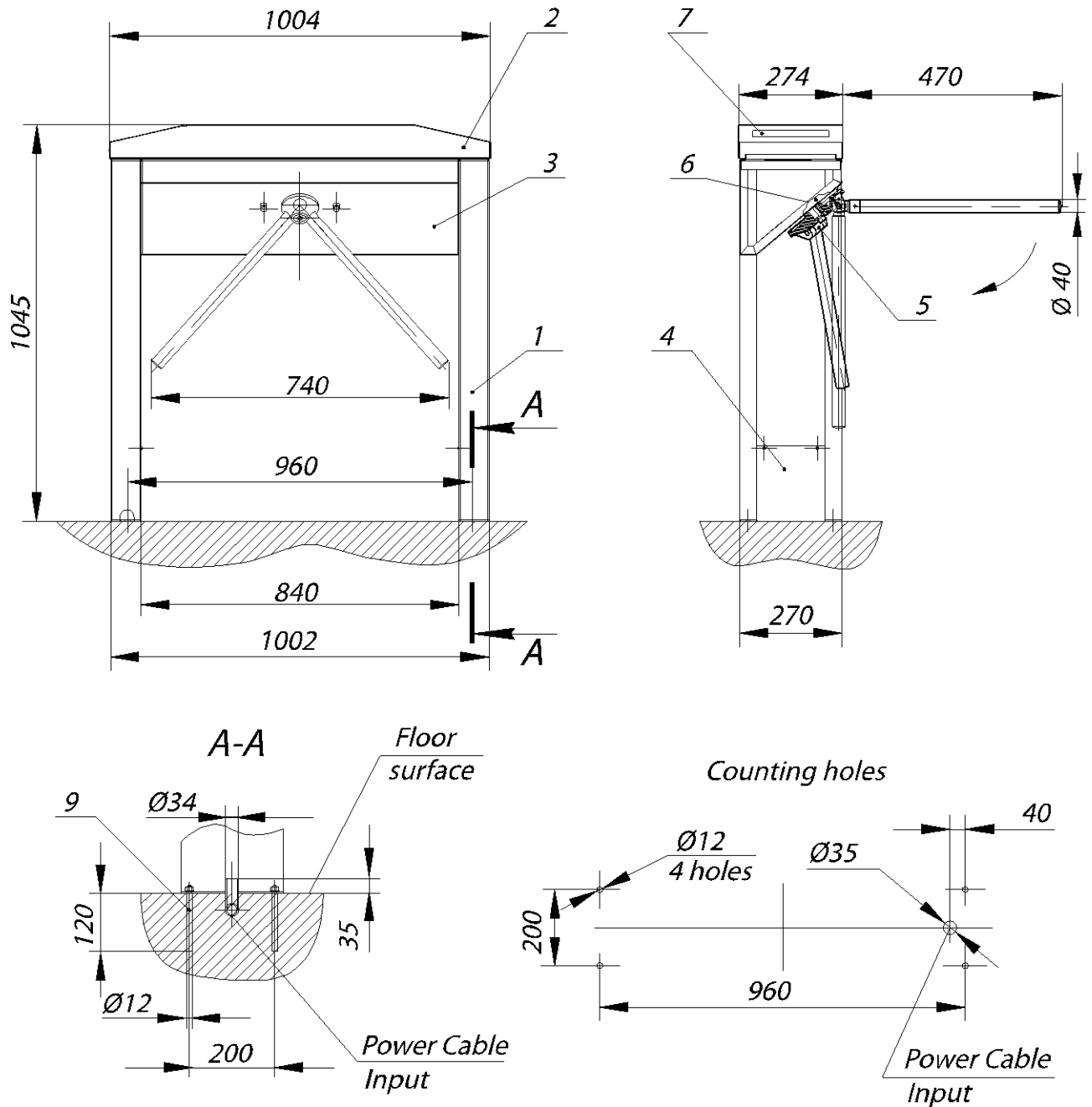

- 1 – post;
- 2 – top cover;
- 3 – housing;
- 4 – side cover;

- 5 – hub with three rods;
- 6 – control mechanism;
- 7 – LED display;
- 8 – anchor Redibolt

Figure A.1 – Tripod Turnstile

Appendix B
Control panel and connection diagram

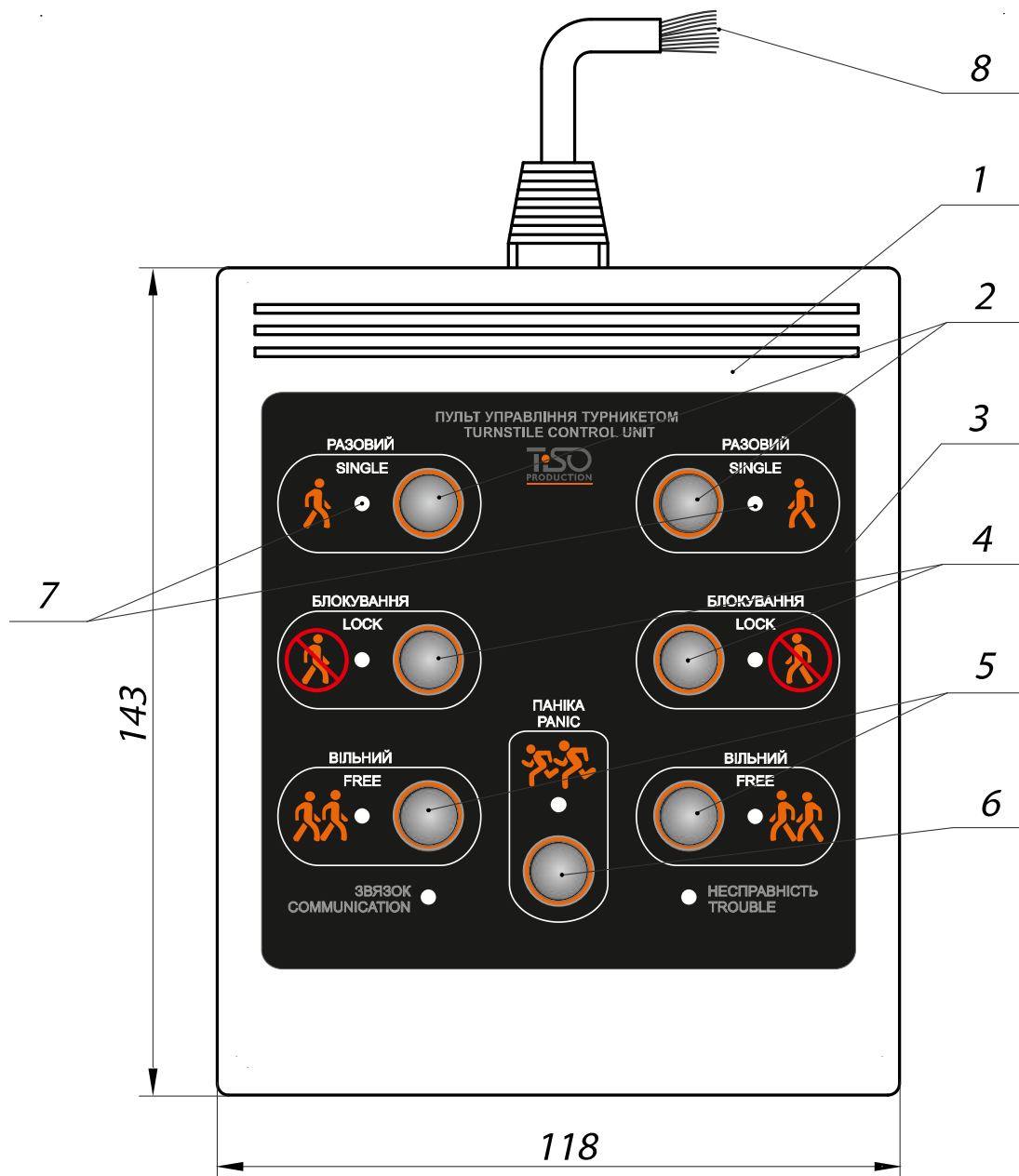

1 – housing;
2 – «SINGLE ACCESS» mode control button;
3 – front plate;
4 – «LOCKING» mode control button;

5 – «FREE ACCESS» mode control button;
6 – «PANIC» mode control button;
7 – access direction LED display;
8 – controller connection terminals

Figure B.1 – Control panel AUIA.114.02.00.00

Appendix C
Wiring Diagram of the Servo-Operated Waist-High Tripod Turnstile

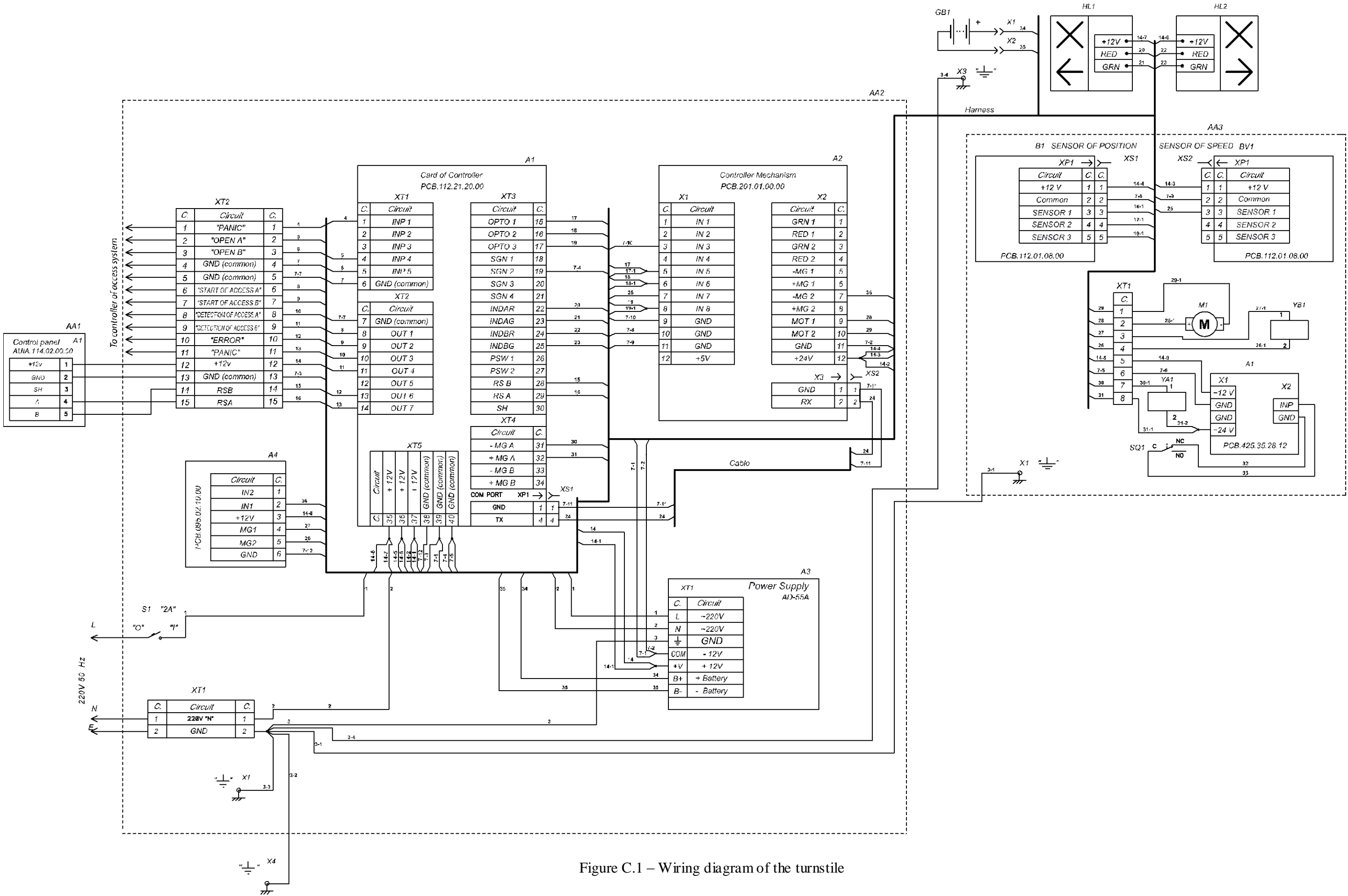

Figure C.1 – Wiring diagram of the turnstile